

15" modero® touch panel



THE NEXT GENERATION

The 15" Modero marks two decades of technology evolution from AMX, including:

- 24-bit color depth
- 8-bit transparency, supporting 256 levels of industry standard "Alpha Channel" blending
- 24-bit color video display that supports NTSC, PAL, SECAM with adjustments for brightness, contrast, saturation and hue
- Seamless animation with 256 modes per button – no external code required
- Customizable graphics including: bargraphs, dials and gauges with the ability to use any border style

GOING WIRELESS

The 15" Modero Table Top Touch Panel includes an optional Battery System that eliminates the power cord. This innovative Battery Base offers the potential freedom and convenience of a truly wireless experience. Simply plug a suggested wireless network card into the PCMCIA card slot located under the access door on the Modero Panel, add a wireless access point and attach the Battery Base for complete wireless control. Refer to the Modero Battery Base Kit and Battery Quick Charger Kit datasheets for more information.



15" modero® touch panel

NXT-CA15 (FG 2252)

LCD

- 15" Color active-matrix LCD (1024 x 768 pixel resolution)
- Viewing Angle: Ultra-wide +85° viewing in all directions
- Dot pixel pitch: 0.297 mm
- Display colors: 16 million (24-bit color depth)
- Active View Area: 11.97" x 8.98" (30.41 cm x 22.81 cm)

POWER

- 3.5 Amps @ 12.0 VDC

MEMORY

- 64MB Extended Memory Module (upgradable to 256MB)
- 64MB Compact Flash (upgradable to 1 GB) factory programmed with panel firmware

DIMENSIONS (HWD)

- 12.942" x 14.950" x 11.720" (32.87 cm x 37.97 cm x 29.77 cm)
- Fully lowered height: 7.4545" (18.92 cm)

ENCLOSURES

- ABS Polycarbonate enclosure in black matte finish with platinum color bezel trim

FRONT PANEL

- Light Sensor: Photosensitive light detector for automatic adjustment of the panel brightness
- Motion Sensor (PIR): Proximity Infrared Detector to wake the panel when panel is approached
- Front Setup Access Button: Pushbutton (grey) used to either put the panel into a "sleep" or "wake" state and/or access the Setup and Calibration pages
- IR Receiver: 38 KHz and 455 KHz AMX IR frequencies
- Speakers: Frequency response 450 Hz - 7 KHz

REAR CONNECTORS

- PCMCIA Card Slot: Provides optional wireless connectivity (with upgrade)
- Headphone Connector: Stereo output through a 3.5mm mini-jack (for use with external speakers)
- Ethernet 10/100 Port: RJ-45 port for 10/100 Mbps communication
- Ethernet 10/100 LEDs: LEDs shows Link and Activity
- ICSNet Connector: RJ-45 connection for ICSNet interface

OPTIONAL ACCESSORIES

- PSN6.5 Power Supply (13.5 VDC)
- Upgrade SDRAM memory:
 - NXA-EXM128M - 128 MB memory card
 - NXA-EXM256M - 256 MB memory card
- Upgrade Compact Flash (factory programmed with firmware):
 - NXA-CFTP128M - 128 MB compact flash card
 - NXA-CFTP256M - 256 MB compact flash card
 - NXA-CFTP512M - 512 MB compact flash card
 - NXA-CFTP1G - 1 GB compact flash card
- NXA-BASE/B: Wireless base for Table Top Touch Panel (NXT versions only)
- NXA-WC80211b: 802.11b wireless interface card
- NXT-BP: Battery pack for Table Top Touch Panel. Provides 4 hours of continual operation (NXT versions only)
- NXT-CHG: Battery charger for NXT-BP batteries. Charges batteries in 8 hours.

WEIGHT

- 14.25 lbs (6.46 kg)

NXT-CV15 (FG 2253-11K)

- Includes all the features of the NXT-CA15 plus:
 - Displays NTSC/PAL/SECAM video formats in variable-size video window
 - Sound option (including speakers and audio/headphone connections)

FRONT PANEL

- Microphone: Used for audio/video conferencing applications

REAR CONNECTORS

- Audio/Video Connector: RJ-45 connector cable for Audio/Video signals from the NXA-AVB Breakout Box
- ICSNet Connector: RJ-45 connector provides an ICSNet signal interface from the NXA-AVB Breakout Box
- Breakout Box (NXA-AVB)
- Included with CV15 touch panel
- Provides video/audio distribution to the CV15 ver CAT5 cable (up to 200 feet)
- Accepts either Composite or S-Video with Adapter

BREAKOUT BOX (NXA-AVB)

- Included with CV12 touch panel
- Provides video/audio distribution to the CV12 over CAT5 cable (up to 200 feet)
- Accepts either Composite or S-Video with Adapter

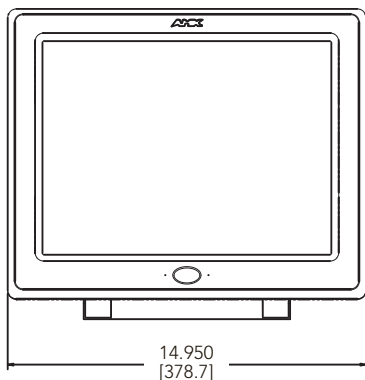

NXT-CA15/NXT-CV15 (Front View)

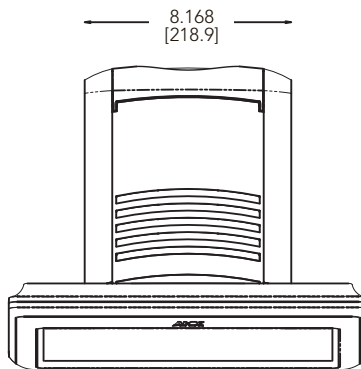

NXT-CA15/NXT-CV15 (Rear View)

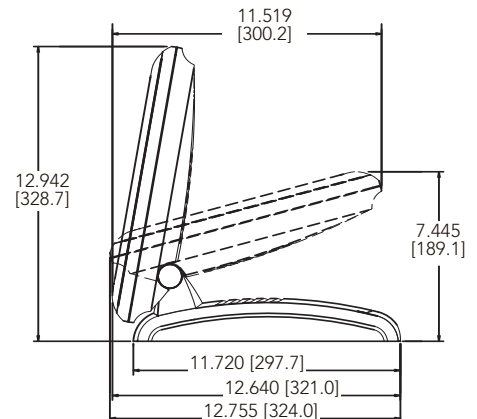

NXT-CA15/NXT-CV15 (Right Side)



IT'S YOUR WORLD. TAKE CONTROL.

ARGENTINA • AUSTRALIA • BELGIUM • BRAZIL • CANADA • CHINA • ENGLAND • FRANCE • GERMANY • GREECE • HONG KONG • INDIA • INDONESIA • ITALY • JAPAN
 LEBANON • MALAYSIA • MEXICO • NETHERLANDS • NEW ZEALAND • PHILIPPINES • PORTUGAL • RUSSIA • SINGAPORE • SPAIN • SWITZERLAND • THAILAND • TURKEY • USA
 ATLANTA • BOSTON • CHICAGO • CLEVELAND • DALLAS • DENVER • INDIANAPOLIS • LOS ANGELES • MINNEAPOLIS • PHILADELPHIA • PHOENIX • PORTLAND • SPOKANE • TAMPA
 3000 RESEARCH DRIVE, RICHARDSON, TX 75082 • 800.222.0193 • 469.624.8000 • +1.469.624.7400 • 469.624.7153 fax • www.amx.com

15" modero® touch panel

NXD-CA15 (FG 2253-10)

LCD

- 15" Color active-matrix LCD (1024 x 768 pixel resolution)
- Viewing Angle: Ultra-wide +85° viewing in all directions
- Dot pixel pitch: 0.297 mm
- Display colors: 16 million (24-bit color depth)
- Active View Area: 11.97" x 8.98" (30.41 cm x 22.81 cm)

POWER

- 3.5 Amps @ 12.0 VDC

MEMORY

- 64MB Extended Memory Module (upgradable to 256MB)
- 64MB Compact Flash (upgradable to 1 GB) factory programmed with panel firmware

DIMENSIONS (HWD)

- Decor faceplate included: 14.37" x 15.20" x 3.31" (36.50 cm x 38.61 cm x 8.40 cm)
- CB-CV15 Conduit/wallbox: 13.48" x 14.18" x 3.49" (34.24 cm x 36.00 cm x 8.85 cm)

ENCLOSURES

- Metal enclosure with ABS Polycarbonate front bezel in black matte finish with platinum color trim

FRONT PANEL

- Light Sensor: Photosensitive light detector for automatic adjustment of the panel brightness
- Motion Sensor (PIR): Proximity Infrared Detector to wake the panel when panel is approached
- Front Setup Access Button: Pushbutton (grey) used to either put the panel into a "sleep" or "wake" state and/or access the Setup and Calibration pages
- Speakers: Frequency response 450 Hz - 7 KHz

SIDE CONNECTORS

- PCMCIA Card Slot: Provides optional wireless connectivity (with upgrade)
- Headphone Connector: Stereo output through a 3.5mm mini-jack (for use with external speakers)
- Ethernet 10/100 Port: RJ-45 port for 10/100 Mbps communication
- Ethernet 10/100 LEDs: LEDs shows Link and Activity
- ICSNet Connector: RJ-45 connection for ICSNet interface

OPTIONAL ACCESSORIES

- PSN6.5 Power Supply (13.5 VDC)
- Conduit Wall box (optional for all NXD touch panels)
- NXA-RK15 Rackmount kit for 15" Decor-style touch panels
- Upgrade SDRAM memory:
 - NXA-EXM128M - 128 MB memory card
 - NXA-EXM256M - 256 MB memory card
- Upgrade Compact Flash (factory programmed with firmware):
 - NXA-CFTP128M - 128 MB compact flash card
 - NXA-CFTP256M - 256 MB compact flash card
 - NXA-CFTP512M - 512 MB compact flash card
 - NXA-CFTP1G - 1 GB compact flash card
- NXA-WC80211b: 802.11b wireless interface card

WEIGHT

- 13.75 lbs (6.24 kg)

NXD-CV15 (FG 2253-12K)

- Includes all the features of the NXD-CA15 plus:
 - Displays NTSC/PAL/SECAM video formats in variable-size video window
 - Sound option (including speakers and audio/headphone connections)

FRONT PANEL

- Microphone: Used for audio/video conferencing applications

SIDE CONNECTORS

- Audio/Video Connector: RJ-45 connector cable for Audio/Video signals from the NXA-AVB Breakout Box
- ICSNet Connector: RJ-45 connection for ICSNet interface
- Breakout Box (NXA-AVB) Included with CV15 touch panel
- Provides video/audio distribution to the CV15 over CAT5 cable (up to 200 feet)
- Accepts either Composite or S-Video with Adapter

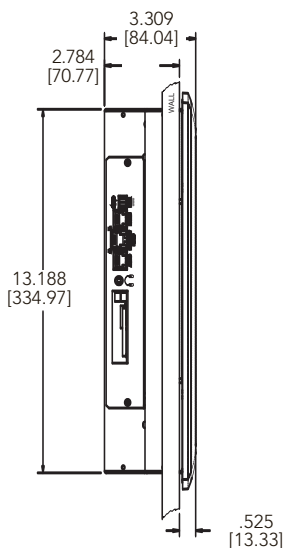

NXD-CA15/NXD-CV15 (Right Side)

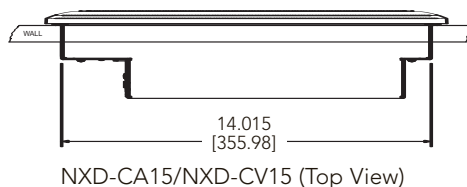

NXD-CA15/NXD-CV15 (Top View)

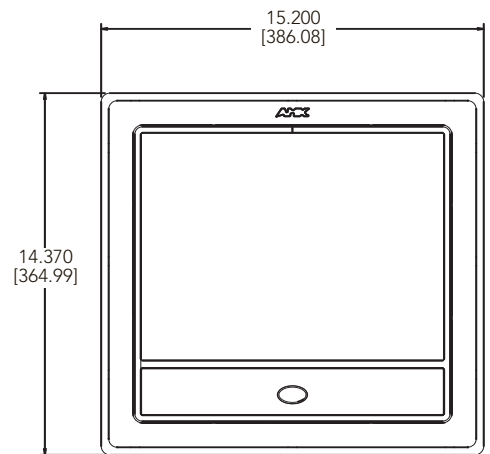

NXD-CA15/NXD-CV15 (Front View)



IT'S YOUR WORLD. TAKE CONTROL.

ARGENTINA • AUSTRALIA • BELGIUM • BRAZIL • CANADA • CHINA • ENGLAND • FRANCE • GERMANY • GREECE • HONG KONG • INDIA • INDONESIA • ITALY • JAPAN
 LEBANON • MALAYSIA • MEXICO • NETHERLANDS • NEW ZEALAND • PHILIPPINES • PORTUGAL • RUSSIA • SINGAPORE • SPAIN • SWITZERLAND • THAILAND • TURKEY • USA
 ATLANTA • BOSTON • CHICAGO • CLEVELAND • DALLAS • DENVER • INDIANAPOLIS • LOS ANGELES • MINNEAPOLIS • PHILADELPHIA • PHOENIX • PORTLAND • SPOKANE • TAMPA
 3000 RESEARCH DRIVE, RICHARDSON, TX 75082 • 800.222.0193 • 469.624.8000 • +1.469.624.7400 • 469.624.7153 fax • www.amx.com